

Item# _____
Project: _____
Qty: _____

Aluminum Dunnage Rack



Features

- Heavy Duty 1½" square aluminum all welded construction
- 1½" x 2" angles
- For use in walk-in coolers and freezers, dry storage, display, etc.
- Extends product life by circulating air underneath
- Capacity up to 2,500 lbs



Cannonware Products
www.cannonware.com

Phone:(800).768.5953

Fax:(800).976.1299

ALUMINUM



Cannonware Products

Item# _____
 Project: _____
 Qty: _____

Aluminum Pan Rack

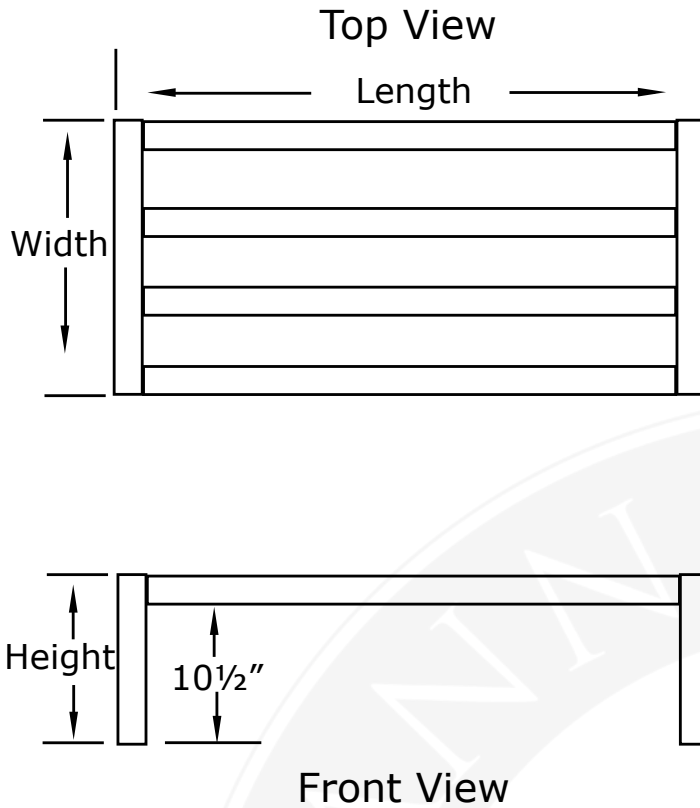

Model	Size (W x L x H)	Capacity	Weight/lbs (Shipping)
CWP-DR-203612	20" x 36" x 12"	2500 lbs	9
CWP-DR-204812	20" x 48" x 12"	2200 lbs	11
CWP-DR-206012	20" x 60" x 12"	2000 lbs	13
CWP-DR-243612	24" x 36" x 12"	2500 lbs	10
CWP-DR-244812	24" x 48" x 12"	2200 lbs	13
CWP-DR-246012	24" x 60" x 12"	2000 lbs	15



Cannonware Products
www.cannonware.com

Phone: (800).768.5953

Fax: (800).976.1299



Cannonware Products