

Item# _____
Project: _____
Qty: _____

Aluminum Transport Cabinet



Features

- 14 Gauge, Natural Finish Aluminum
- Heavy Duty Riveted Construction
- 270° Door Swing with Side Wall Door Stay
- 40 Pan Capacity
- Fits 26" x 18" Pans
- Ideal For Healthcare, Food Service, or Restaurant Applications
- Complete With 4" NSF Casters, Two With Locking Brake



Cannonware Products
www.cannonware.com

Phone:(800).768.5953

Fax:(800).976.1299



Cannonware Products

Item# _____
Project: _____
Qty: _____

February 2009

Aluminum Cabinet

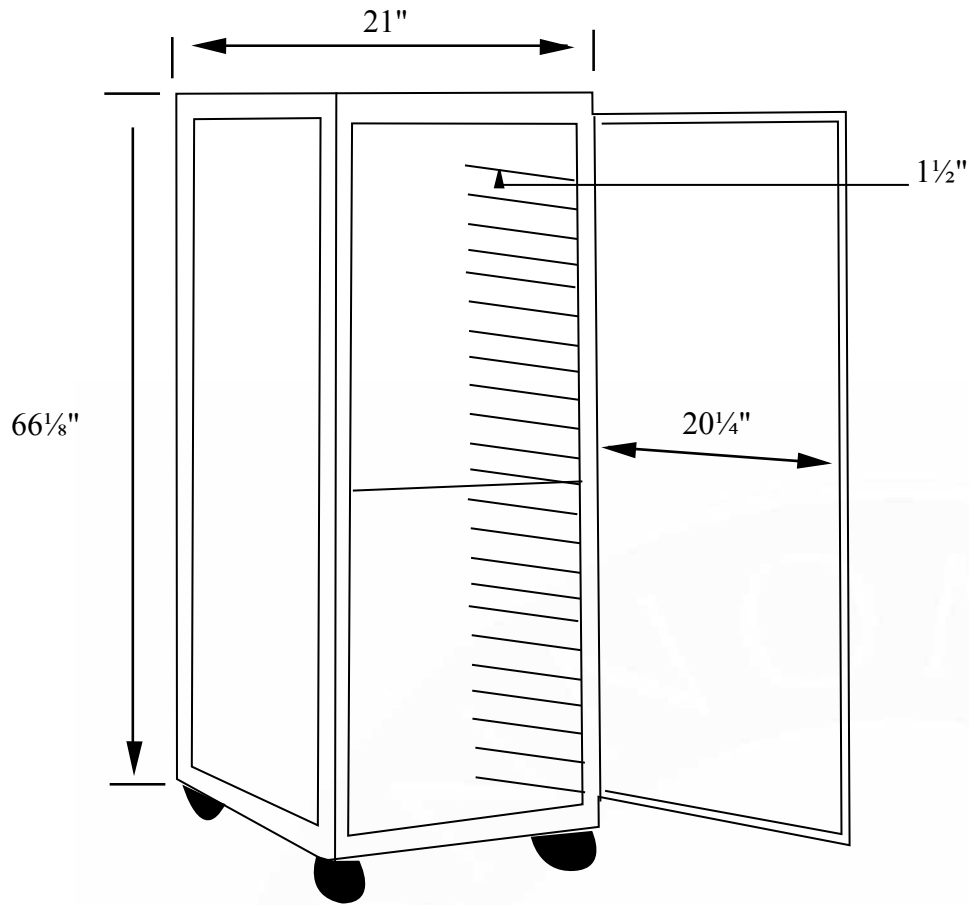

Fits 26" x 18" Pans

Cannonware Products

Model

CWP-EC-40EL

Description

40 Pan Aluminum
(non-heated/non-insulated)

Weight/lbs

(Shipping)
82



Cannonware Products
www.cannonware.com

Phone:(800).768.5953

Fax:(800).976.1299

